

REVISION HISTORY

REV	DESCRIPTION	DATE	APPROVED

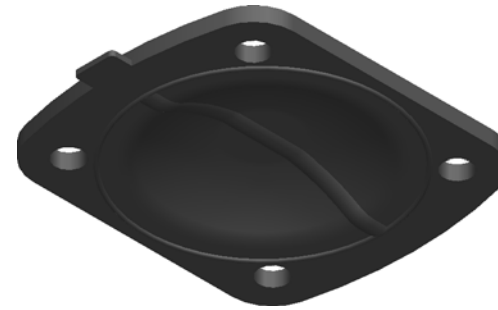
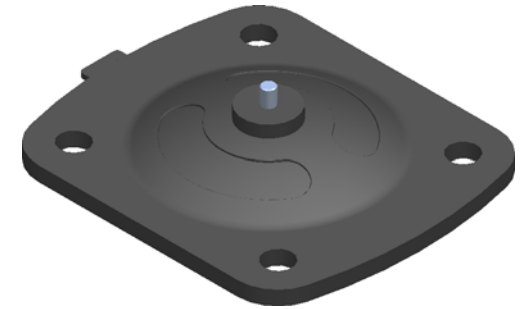
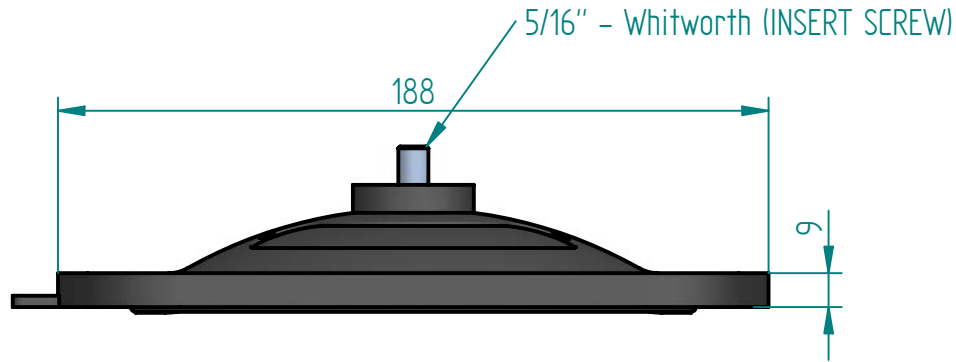

Scale  
1:3.33

Replacement Diaphragm for :-

Grade : FPM/FKM - FDA

USED ON 3" (DN80) Diaphragm Valve

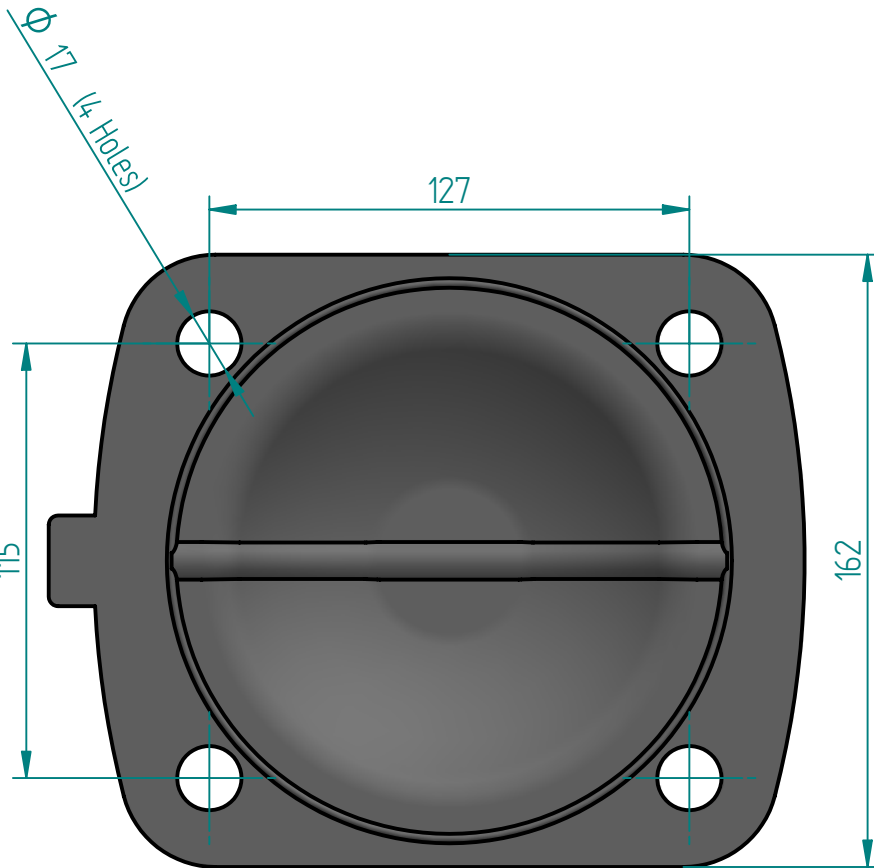

	NAME	DATE
DRAWN	M.MC KEON	01/21/15
CHECKED		

**Material - FPM/FKM**

FDA Compliance :  
21 CFR 177.2600



TITLE  
**DD30-SFPM**

SIZE A	FOOT PRINT DIMENSIONS	REV B
-----------	-----------------------	----------

FILE NAME: DD30-SFPM.dft

SCALE: 1:2 (mm)	ECD:0605	SHEET 1 OF 1
-----------------	----------	--------------

Disclaimer - Diaphragm Direct® does not manufacture, represent, nor sell OEM valves or diaphragms manufactured by any other company. Diaphragm Direct® brand diaphragms are not sponsored by any other manufacturers. Any name, model, part number, brand, image, material or referral is for descriptive purposes only. Diaphragm Direct® brand replacement diaphragms are guaranteed to fit OEM equipment and meet or exceed OEM specifications. Diaphragm Direct® brand replacement diaphragms are covered by the standard Diaphragm Direct® limited product warranty.